



# Community Radio Licence Application Form

East End Broadcast

- A. Please read the Notes of Guidance for Community Radio Licence Applicants before completing this form. For assistance with individual questions, please refer to the relevant sections of the application notes which accompany this form.**
- B. Please read this document carefully and then answer all the questions as fully and accurately as possible.**
- C. Please complete this form in English. One typed copy should be sent by e-mail to: [communityradio@ofcom.org.uk](mailto:communityradio@ofcom.org.uk) (if it is not possible to e-mail your application, please send one typed copy to the address below).**
- D.** Applications will be made available for public inspection on Ofcom's website. Details of which parts of an application may be submitted in confidence are included on the first page of the 'Application Notes' which accompany this form. If you wish to submit any information in confidence other than that which is indicated in the Application Notes, as being specifically permissible in such a form, confirmation that this is acceptable must be sought in advance, in writing from Ofcom's Community Radio Licensing Team.
- E.** If you are completing the form on behalf of some other company, please make this clear in an accompanying letter. You will need to provide evidence of your authority to act on behalf of the applicant. The form should be filled in so as to include information about the applicant, not about you acting on their behalf.
- F.** Sufficient information must be supplied about the identity, composition and ownership of the applicant and any body which controls the applicant to ensure that the applicant may hold a community radio licence granted under the Broadcasting Act 1990 (as amended) in accordance with the Communications Act 2003 and under the Community Radio Order 2004. Before a licence is granted, further details may be required.
- G.** In submitting this application you agree that, should a licence be granted, Ofcom may publish contact details for the licensee (specified in section 2.6 of this application form), which may include personal data, on the Ofcom web site and/or in other relevant publications.
- H.** This application form covers the requirements of the Broadcasting Act 1990 (as amended) and the Wireless Telegraphy Act 1949. If the application is successful you will be issued with both a Broadcasting Act licence and a Wireless Telegraphy Act licence.

Community Radio Licensing, Radio Planning & Licensing Team  
Ofcom  
Riverside House  
2A Southwark Bridge Road  
London SE1 9HA.

**SECTION ONE. OPENING STATEMENT.**

**1.1** Opening Statement.

Please provide a short introductory statement summarising the target community, the objectives of the service, and its broadcasting philosophy.

**(For more information please refer to section 1.1 of the accompanying notes).**

The East End Broadcast is based in the Barrowfield district of the East End of Glasgow. The Broadcast project was created in 2002 to engage the wider community of the East End of Glasgow in IT and Broadcast Skills training via the medium of an Internet Radio Station with the ultimate aim of becoming a full time FM Radio Station for the East End. Our programmes are a mix of locally made items by Community Groups, Schools, Local agencies such as Addiction Services, Youth Projects and Pensioners Groups as well as live music based shows presented by our Trainees and Volunteers.

*Please continue to Section Two on next page.*

## SECTION TWO – About your organisation and how to contact you.

Ofcom needs information about your organisation and needs to be able to contact you.

**(For more information about the individual questions below, please refer to sections 2.1 to 2.7 of the accompanying notes).**

### 2.1 Proposed Name of Station

East End Broadcast

### 2.2 Contact Address

The Bambury Regeneration  
67 Yate St  
Glasgow

Centre  
Camlachie  
You **must** include the postcode | G31 4AE

Is this address:

The main address of your organisation?           ? Yes  
The registered office of your organisation?        ? Yes  
The home address of the main contact?            ? No

Other contact details for your organisation, as applicable:

Phone (work)           01415503954      Phone (home)             
Mobile number                                                 Fax number           01415504113  
E-mail address    info@eeib.org  
Website address           www.eeib.org

### 2.3 Contact Name

Sam Paterson

*Section continues on next page...*

**2.4** Company Details: What type of organisation are you? Please tick the appropriate boxes and provide the additional information requested.

Company Limited by Guarantee	<b>Yes</b>	Waiting to be registered	?
OR Registration Number:	<input type="text" value="SC190755"/>		
Date of Registration or Application:	<input type="text"/>		

Company Limited by Shares	?	Waiting to be registered	?
OR Registration Number:	<input type="text"/>		
Date of Registration or Application:	<input type="text"/>		

**2.5** Is your organisation a registered charity in England, Wales, Scotland or Northern Ireland? If so, please provide details here.

Registered Charity	<b>Yes</b>	Waiting to be registered	?
OR Registration Number:	<input type="text" value="SC028385"/>		
Date of Registration or Application:	<input type="text"/>		

**2.6** Public Contact Details.

For publication on the Ofcom website and/or in other relevant publications (published either by Ofcom or third parties directed by Ofcom) should a licence be granted.

Contact Name

Sam Paterson
--------------

Contact Address

East End Broadcast		The Bambury Regeneration Centre	
67 Yate St		Camlachie	
Glasgow		You <b>must</b> include the postcode	G31 4AE

Other contact details for your organisation, as applicable:

Phone number:	01415503954	Mobile number:	
Fax number:	01415504113	E-mail address:	info@eeib.org
Website address:	www.eeib.org		

*Section continues on next page...*

**2.7** Supporting Documentation.

Ofcom needs to check that your organisation is eligible to operate a Community Radio service. Please tick the appropriate boxes to show which of the following documents you have provided:

Certificate of Incorporation

?

Memorandum & Articles of Association

Yes

(Please make sure you include your organisation's name and postcode on the front page of the constitutional document(s) provided.)

*Please continue to Section Three on next page.*

### SECTION THREE – Ownership.

Please provide the following information in relation to the directors of the applicant group.

**(For more information about the individual questions below, please refer to sections 3.1 to 3.15 of the accompanying notes).**

#### DIRECTORS

**3.1** Name of member or director

David McDermott

**3.2** Contact Address

1 The Auld Kirk  
Carmunnock Road  
Glasgow

You **must** include the postcode | G76 8TB

Other contact details

Phone number | 01415503954 | Mobile number |

Fax number | 01415504113 | E-mail address | davidmcdermott@thebambury.org

**3.3** Other Employment

Chief Executive – Bambury Regeneration Centre

**3.4** Relevant interests

Social and economic Regeneration  
Football  
Reading

**3.5** Expected Role in Community Radio Station

Overall Management – Member of Steering Group - Synchronisation with Bambury Centre Main Funding Strategy

**PLEASE REPEAT QUESTIONS 3.1 – 3.5 FOR EACH DIRECTOR OF THE APPLICANT GROUP**

*Section continues on next page...*

### SECTION THREE – Ownership.

Please provide the following information in relation to the directors of the applicant group.

**(For more information about the individual questions below, please refer to sections 3.1 to 3.15 of the accompanying notes).**

#### DIRECTORS

##### 3.1 Name of member or director

Archie Biggins

##### 3.2 Contact Address

53 Frazer St	
Glasgow	You <b>must</b> include the postcode   G40 3QS

##### Other contact details

Phone number	01415503954	Mobile number	
--------------	-------------	---------------	--

Fax number	01415504113	E-mail address	archiebiggins@thebambury.org
------------	-------------	----------------	------------------------------

##### 3.3 Other Employment

Deputy Chief Executive - Bambury Regeneration Centre

##### 3.4 Relevant interests

##### 3.5 Expected Role in Community Radio Station

Line Management within Bambury Centre. Advisor on H+S Legislation.  
Allocation of resources and accommodation within Bambury Centre

**PLEASE REPEAT QUESTIONS 3.1 – 3.5 FOR EACH DIRECTOR OF THE APPLICANT GROUP**

*Section continues on next page...*

### SECTION THREE – Ownership.

Please provide the following information in relation to the directors of the applicant group.

**(For more information about the individual questions below, please refer to sections 3.1 to 3.15 of the accompanying notes).**

#### DIRECTORS

**3.1** Name of member or director

Anna Marie Campbell

**3.2** Contact Address

91 Zena St	
Barmulloch	
Glasgow	You <b>must</b> include the postcode   G33 1HY

Other contact details

Phone number  Mobile number

Fax number  E-mail address

**3.3** Other Employment

Training Development Officer – Bambury Centre

**3.4** Relevant interests

Training  
Community Regeneration  
Music

**3.5** Expected Role in Community Radio Station

Advisor Re: Training Programmes and Development.

**PLEASE REPEAT QUESTIONS 3.1 – 3.5 FOR EACH DIRECTOR OF THE APPLICANT GROUP**

*Section continues on next page...*

### SECTION THREE – Ownership.

Please provide the following information in relation to the directors of the applicant group.

**(For more information about the individual questions below, please refer to sections 3.1 to 3.15 of the accompanying notes).**

#### DIRECTORS

##### 3.1 Name of member or director

William Murray

##### 3.2 Contact Address

126 Stamford St	
Camlachie	
Glasgow	You <b>must</b> include the postcode   G31 4AE

##### Other contact details

Phone number  Mobile number

Fax number  E-mail address

##### 3.3 Other Employment

none

##### 3.4 Relevant interests

Football  
Fishing

##### 3.5 Expected Role in Community Radio Station

Member of Steering Group. Representing Local Community and Bambury Board.

**PLEASE REPEAT QUESTIONS 3.1 – 3.5 FOR EACH DIRECTOR OF THE APPLICANT GROUP**

*Section continues on next page...*

### SECTION THREE – Ownership.

Please provide the following information in relation to the directors of the applicant group.

**(For more information about the individual questions below, please refer to sections 3.1 to 3.15 of the accompanying notes).**

#### DIRECTORS

**3.1** Name of member or director

Tracy Biggins

**3.2** Contact Address

Flat 0/2  
18 Overtown St.  
Glasgow

You **must** include the postcode | G31 4AN

Other contact details

Phone number 01415503954 Mobile number

Fax number 01415504113 E-mail address tracybiggins@thebambury.org

**3.3** Other Employment

Finance Director – Bambury Regeneration Centre.

**3.4** Relevant interests

**3.5** Expected Role in Community Radio Station

Financial/Budget Control

**PLEASE REPEAT QUESTIONS 3.1 – 3.5 FOR EACH DIRECTOR OF THE APPLICANT GROUP**

Section continues on next page...

### SECTION THREE – Ownership.

Please provide the following information in relation to the directors of the applicant group.

**(For more information about the individual questions below, please refer to sections 3.1 to 3.15 of the accompanying notes).**

#### DIRECTORS

##### 3.1 Name of member or director

Sam Paterson

##### 3.2 Contact Address

83 Finlay Drive	
Dennistoun	
Glasgow	You <b>must</b> include the postcode   G31

##### Other contact details

Phone number  Mobile number

Fax number  E-mail address

##### 3.3 Other Employment

##### 3.4 Relevant interests

Music  
Community Development  
Education  
Employment  
Cultural Development  
Arts/Multi Media  
E-Democracy

##### 3.5 Expected Role in Community Radio Station

Project Manager

**PLEASE REPEAT QUESTIONS 3.1 – 3.5 FOR EACH DIRECTOR OF THE APPLICANT GROUP**

*Section continues on next page...*

**3.6** Please provide the names and addresses of the members of the company. If the applicant is a company limited by shares, this information should be provided in respect of participants with an interest of more than 5 per cent in the applicant, as well as participants with an interest of more than 5 per cent in any body which controls the applicant.

N/A

Please state whether the applicant or any member about whom information has been provided under question 3.6 above is involved in any of the activities listed below, and give the extent of such interest. For these purposes the applicant includes associates of the applicant (i.e. directors and their associates and other group companies). If any of the following categories do not apply, applicants must still complete this section, clearly indicating that this is the case by writing **'none'** in each such section.

**3.7** Local Authorities

N/A

**3.8** Bodies which are wholly or mainly of a political nature, or which are affiliated to such a body:

N/A

**3.9** Bodies whose objects are wholly or mainly of a religious nature:

N/A

**3.10** An individual who is an officer of a body falling within 3.9 above:

N/A

**3.11** An advertising agency or an associate of an advertising agency:

N/A

*Section continues on next page...*

**3.12** Other Broadcasting Act licensees, specifying which licences:

N/A

**3.13** Affiliations with other bodies not outlined above, (for example related charities or community groups):

N/A

**3.14** Other matters which may influence the application.

Ofcom requires that applicants should, at the time of making this application, notify Ofcom of any matters which might influence Ofcom's judgement as to whether:

- a) any director/manager or the applicant group,  
or,
- b) any individual, or any director of a company, who will have an interest of 10 per cent or more in the applicant group

may not be considered a 'fit and proper person' to participate in a radio licence.

Tick here if there are no reasons why Ofcom might consider the applicant not to be a fit and proper person to participate in a radio licence:  ?

**If you have not ticked the above box, please provide details on a separate sheet, such that this information may be kept confidential by Ofcom.**

**3.15** Has the applicant made any other application to Ofcom (or its predecessor broadcast regulators – the ITC and the Radio Authority) for any licence within the last five years? If so, provide the licence reference number(s) and / or the name(s) of the service(s) for granted licence(s).

Tick here if the Answer is No

**NO**

If you have not ticked the above box, please provide details of here

*Please continue to Section Four on next page.*

## **SECTION FOUR – Management.**

Please provide details of those individuals who will be responsible for management and policy-making process.

### **4.1 Details of board, management committee or equivalent:**

Bambury Board Of Directors

Chief Executive

Assistant Chief Executive

East End Broadcast Steering Group (Funders, Representatives from Community Projects, Training Providers, Community Volunteers, Project Manager, Assistant Co-ordinator)

*Section continues on next page...*

**4.2** Indication of Staff structure, to include numbers of unpaid, (volunteer) staff positions and number of paid staff (if any):

**Multi Media Manager** (Sam Paterson) F/T – Overall Coordination of Project, Outreach, Training Courses, Marketing, Community Engagement and Project Development.

**Station Coordinator** (Iain Boyce) F/T – Supervision Of Broadcast Material Creation, Live and Pre-Recorded Programme Scheduling, Technical Maintenance, Technical Planning and assisting in Project Development.

**Admin/Tech Assistant** (Paul Peacock) P/T – Website maintenance, IT support, General Admin, Archiving Broadcasts.

**Broadcast Engineer/Tutor** (John P Martin) P/T – Recording and editing of Broadcast Material, Teaching Volunteers and Trainees in Recording and Editing, Supervision of Live Broadcasts, maintaining the Output Stream.

**Admin Trainee** (Donna Farrell) F/T – Filing, Collation of Information for Manager. Report Typing, Supervision of equipment Hires and Loans to Individuals and Community Groups.

**Project Trainee** (Thomas Boylan) P/T – Editing of audio and Video material, Copying of Discs, attending training sessions as required.

**John Wheatley College Tutors** (Johnathan Stanley - Andy Phillips – Hugh O'Rourke - Ali Bell – Gareth Dunn ) – Provision of tuition to Trainees, Volunteers and Community organisations as identified by Project Manager

**Youth Music IT Worker** (Funding Pending) P/T – Engaging Young People from the local Community in Music IT activities and Broadcast Skills, Creation of Young People's Programming Group with power to decide content for dedicated youth time slots.

**Youth IT Support Worker** (Funding Pending) P/T – Engaging Young People in IT training and supporting the Music IT activities.

**Vol Presenters** (Unpaid) - Gary McKean, Katrina Boyce, Bunstan McFunstan, Susan Milligan, Jackie Hay, Chris Irving, Natalie Nimmo, Stuart Allen, Ron McKenzie, Chris McCartney, Dave Thomson, Simon Burt (aka DJ Equinox), John P Martin (aka DJ Bunnet), Paul Buchanan. Ray C Ward.

*Please continue to Section Five on next page.*

## **SECTION FIVE – Community to be served**

The Community Radio Order 2004 defines a ‘community’ as

- (a) the persons who live or work or undergo education or training in a particular area or locality,
- or,
- (b) persons who (whether or not they fall within paragraph (a)) have one or more interests or characteristics in common.

**(For more information about the individual questions below, please refer to sections 5.1 to 5.3 of the accompanying notes).**

### **5.1 Description of the Target Community (or Target Communities).**

Residents (of all age groups including children young people, and older people) living in the East End of Glasgow which includes the areas of Barrowfield, Parkhead, Tollcross, Shettleston, Dalmarnock, Bridgeton, Dennistoun, Gallowgate, Geenfield, Liliybank, Carmyle, Townhead, Calton, Haghill, Carntyne, Ballieston, Garrowhill,

### **5.2 Community Demographics.**

The East End of Glasgow has a population of approximately 100000 and includes 15% of the worst enumeration districts in Scotland. It has several areas of multi-deprivation and disadvantage which experience a cocktail of poverty related factors including: unemployment/long term unemployment, child poverty, benefit dependency (Glasgow City Council wards in the East End have over 50% of their population of working age dependant on benefits or Job Seekers Allowance), low educational attainment (60% of respondents to a case study had no qualifications and only 6% had attained any Highers) and poverty related health problems (13% of babies with low birth weight, 20% lower rate of GP registrations). Many families experience problems that are directly related to drug and/or alcohol abuse (Methodone prescriptions increased three-fold in the late 1990's). A survey on the Scottish Executive website stated that 53% of men aged 18 – 65 and 57% of women of the same age group felt that it was unsafe to be outside during the hours of darkness.

Sources – Slims 2002, Futureskills Scotland: Skills in Scotland 2002, the Employers View, Glasgow Economic Monitor, East End Partnership Annual Report 2003.

**5.3 Evidence of Local Demand and Support:**

**( Please Note that due to equipment failure we have been unable to scan these documents and will therefore be sending them by post)**

Letters From:

Local Councillor Elaine Smith,  
Cllr David Stephenson,  
MSP Frank McAveety,

Local Agencies :

East End Partnership,  
Glasgow City Council Youth Services,  
John Wheatley College  
Urban Fox  
South Camlachie Neighbourhood Forum  
Bambury Centre Board of Directors  
GCC Community Safety Team  
Strathclyde Police Community Liason  
East End Social Inclusion Partnership  
Bridgeton CAB

Collated Information from Community Radio Survey

*Please continue to Section Six on next page.*

## **SECTION SIX – Social Gain, Accountability and Access to Station.**

Every applicant for a community radio service must demonstrate that the proposed service would be provided primarily for the good of members of the public, or of the target community, and in order to deliver social gain. Applicants must provide evidence that their proposed service would result in the delivery of significant social gain to the public, or the target community. In addition, when deciding whether or to whom to award a community radio licence, one of the criteria to which Ofcom must have regard is the extent to which the proposed service would result in the delivery of social gain to the target community. The Community Radio Order lists four mandatory social gain objectives and a further (non-exhaustive) list of seven other social gain objectives that may be applicable.

Please use the first three questions in this section (boxes 6.1 to 6.3) to answer general questions about how the applicant proposes to serve its target community.

Explain (in boxes 6.4 to 6.7 below) how you propose to meet the four mandatory social gain objectives and explain (in box 6.8 below) what additional social gain objectives (if any) you intend to include as social gain objectives for your proposed service. For each of the objectives, please specify the nature of the targets involved and outline how you expect these to be achieved.

In addition to social gain objectives, when considering applications, Ofcom is required to have regard to various underlying characteristics which define community radio services, some of which are relevant to this section of the application form, (boxes 6.9 and 6.10 below).

In addition to the social gain objective concerning training for members of the target community or the wider public (box 6.6), the Community Radio order 2004 contains a further, slightly different, reference to training as a selection criterion. Ofcom is required to have regard to provision of training in the use of station facilities by members of the target community.

Finally, this section of the application form also gives applicants the opportunity to detail other forms of community involvement (boxes 6.12 to 6.14).

**(For more information about the individual questions below, please refer to sections 6.1 to 6.14 of the accompanying notes).**

**6.1** Addressing Community Needs. Please give a general overview of how you propose to ensure that your service will address community needs. In particular, the extent to which the service would cater for the tastes and interests of the target community, and broaden the range of programmes available by way of local services in the area to the target community.

The EEB will broadcast a mix of music/entertainment and locally produced community centred programmes. These programmes will centre on very specific local services, (previous items have included, school closures, changes to local Health Service GP out of Hours Services, Information on the formation of local Community Safety Committees, Advertisements for Working Links local initiatives in the Parkhead area.) In addition the work of our Music IT outreach classes with various local Youth Groups and Schools will be collated and broadcast on a regular basis.

While there are several commercial local radio stations that provide information etc, this is done on a city or region wide basis. The majority of our programming will be specifically focussed on and in the East End.

We are forging strong links with the Scottish Refugee Council and shall be

including asylum seekers and refugees residing in the East End in making programmes which can be broadcast on FM and on the internet as well as being passed on to organisations in their country of origin ( i.e. Sudan) to facilitate contact with home.

*Section continues on next page...*

## 6.2 Targets and Milestones

- EEB will provide 40 more places on the Sound Idea Course between now and July 2005 in partnership with John Wheatley College.
- We intend to provide 20 Work placements for Training For Work trainees each year, starting from Jan/Feb 2005. (in partnership with GCVS, MI Technologies etc. and John Wheatley College.)
- We will engage 250 people throughout the East End with our Outreach Programme in partnership with John Wheatley College and several Agencies and Service Providers such as MAP, Glasgow Association on Mental Health, Right Track and Scotia Clubhouse.
- We will provide work placements for up to 10 Schoolchildren from the East End each year.
- The programming group will review programming policy every six months, responding to the Broadcast Service questionnaires that we will be making available in local Community Centres and Libraries etc. as well as collated information taken from our website forum and e-mails.
- Milestones will include: Roadshows and first Outside Broadcast at the East End Festival (Summer 2005)
- Expansion of live broadcasting hours from 10am – 8pm to 8am –10pm and then 6am – midnight over the first two years.
- Outreach provision will be monitored regularly and discussed at our Steering Committee meetings every six to eight weeks.

## 6.3 Numbers Involved

By the time we go on air we intend to have 25 regular Volunteer Presenters and Editors working for us. We will look to expand this to 50 or more over the following 18 months.

By this time we also wish to have 2 more Part Time Broadcast Tech Support Workers and One F/T or 2 P/T Web Content Editors. We expect this to increase to either 4 Part Time or 3 Full Time Tech Support Workers by the time we go to 18 hours of live broadcasting per day.

In addition to the training specified above, all Volunteers will be given general training in Broadcast Skills as well as specific training for their preferred role within the project (i.e. Presenting, Engineering, Marketing, Web Content)

**6.4 (Mandatory social gain objective)** Explain how you have identified your target audience(s) (defined in Section 4) as including individuals "who are otherwise underserved" and explain what appropriate radio programming you intend to provide.

There is a high incidence of people who are living on incapacity benefit within the area as well as pensioners and lone parents who can become prisoners in their own homes. EEIB will provide programming on local issues such as access to Council and Health Services, Announcements of and reports on local Public Meetings, Local School and Community Events.

We have had discussions with the local Citizens' Advice Bureau and will be training their staff to come in and participate in live broadcasts of Advice on benefits and legal issues.

**6.5 (Mandatory social gain objective)** Explain how your proposed service will "facilitate discussion and the expression of opinion".

We have a Public Forum on our website which we intend to use as a Talking Shop for community issues.

We also intend to have Phone-in programmes and establish a Phone Text link as well as e-mail direct to the studio.

Any member of the East End Community who wishes to be heard on a subject may come in and arrange to record their comments. (We will do our best to air these subject to broadcasting code.)

A member of EEIB staff regularly attends meetings of the local Neighbourhood Forum where pertinent local issues are discussed and identified to the Project.

The Bambury's Learning Centre has facilitated capacity building programmes for over 1000 Local people and Staff over the past 2 Years, including, Personal Development, Core Skills, Literacy, Numeric, and Volunteer Development Programmes thus allowing various means by which members of the local Community have been empowered to create several representative interest groups such as the Over 50's Club, the New Fossils (Grandparents as carers) and the South Camlachie Youth Project.

*Section continues on next page...*

**6.6 (Mandatory social gain objective)** Explain how you propose to provide education and / or training to individuals not employed by your organisation.

In partnership with John Wheatley College, we currently run several Outreach Programmes in Broadcast Skills, Music IT and introductory level IT Courses, and have delivered IT and Media skills training to over a hundred local groups and organisations over the past 2 years.

We also run "Sound Idea" a 15 week ESF funded Multimedia Training Course. Running for 15 months from Apr 2004 it is designed to provide Multimedia training for up to 60 unemployed people from the Glasgow area.

We will continue to provide innovative of training opportunities whilst looking to develop courses to NC level and HNC after 2 years.

**6.7 (Mandatory social gain objective)** How do you propose to build a better understanding of your target community and strengthen links within it?

We have a Steering Committee which largely consists of representatives from Local Groups, Organisations and Service Providers. (incl. Glasgow City Council Youth Services, South Camlachie Youth Project, Social Work Dept. Addiction Services)

As we reach a wider audience with an FM licence we intend to expand the membership of this committee.

We also have a forum on our website on which we will encourage listeners to respond to issues raised in broadcasts.

Strengthen our links with agencies such as Social Work, NCH, Youth Justice Team, CAB, Youth Services, Addiction Team, Pensioner's Action Group East, Scotia Clubhouse (Mental Health Organisation) and Local Neighbourhood Forums.

**6.8 (Additional social gain objectives)** Please include here details of any other ways in which your station intends to deliver social gain.

By participating in the general arts community in the East End we intend to help promote arts provision in the area, including taking an active role in developing the East End Festival, showcasing local talent via roadshows and staging live concerts in Venues around the East End. We will also help in the promotion of charitable causes and events in the East End.

By rolling out our services to the entire East End Community we will seek to challenge the very real problem of territorialism that exists amongst young people and many adults in the area.

It is also our policy that, where possible, we will employ local people in any paid positions that we are able to achieve funding for.

**6.9 (Community Radio characteristic)** How do you propose to provide members of your community with "opportunities to participate in the operation and management of the service"?

We have a Programming Group made up of Volunteers and Trainees from the project, whose responsibility is to look at the mix of programmes and styles and recommend what future programming should be scheduled/made. Anyone who is involved with the project is welcome to join this group.

Training in Ofcom Guidelines will be included in the induction of all broadcast participants and staff.

Our Steering Committee (examples of membership above) is predominantly made up of representatives of local groups, organisations and service providers.

*Section continues on next page...*

**6.10 (Community Radio characteristic)** How do you propose to ensure that the intended community radio service "is accountable to the community it is intended to serve"?

As previously mentioned, we run a community forum on our website. We also have the facility on the website to run polls on various issues.

We keep a suggestion box in the reception area of the Centre in which we are based.

People can also e-mail us via our website.

We intend to issue a survey questionnaire around the local community centres and libraries etc. every six months. This will also be available to complete online.

**6.11 (Statutory selection criterion)** What provision do you intend to make to allow for access by members of the target community to the facilities to be used for the provision of the service, and for their training in the use of such facilities?

Any person living and/or working in the East End of Glasgow can come in and volunteer with the project. We will train people in the use of the relevant equipment and as soon as they feel ready we will enable them producing pre-recorded work or presenting live shows.

We will include the invitation to do such things in our publicity materials which will be distributed throughout various community venues throughout the East End.

**6.12 Other (Broadcast) Community Radio Objectives**

Delivery of outside broadcasts from major community events.

Live/edited broadcasts of public meetings where appropriate.

Establishment of an East End Audio Archive. (Working with Pensioners Groups and Youth Groups to record reminiscences and gather recordings from previously run projects)

To provide a positive image of the east end of Glasgow and the community within it.

To Provide Public Service Information on behalf of local services, projects etc.etc. involving service users, staff and volunteers.

To provide information and training in order to enable people living or working in the east end to participate in broadcasting and to encourage others to participate.

*Section continues on next page...*

### **6.13 Other (Non-Broadcast) Community Activities**

Empowerment and capacity building of local people by:-

Working within an organised Committee structure and having the mandate to make decisions.

Increasing the employability of local people by giving them a platform on which to exhibit their reliability and suitability for work.

Enabling people to learn more about the Creative Industries associated with broadcasting and ICT.

To raise aspirations of individuals by offering various learning opportunities and social interactions during training and work assignments.

We encourage our trainees and volunteers to try to experiment with programme formats and give them a free range (within the Broadcast Code) to produce different styles of programme as well as conventional music or interview programmes.

### **6.14 Other Information**

The EEIB and the Bambury Learning Centre work in close partnership with John Wheatley College with the intention of offering our trainees and volunteers the opportunity to gain qualifications as they work with the project. The intention of this is to give local people the chance to enter Further Education should they wish to do so thus improving their employability and quality of life.

The Bambury Provides a cocktail of flexible learning to suit groups and individuals who are unlikely to pursue Further Education within the main Campus at present due to lack of confidence and other disadvantages. The project currently can provide up to 96 Lecturers hours per week as part of the Service Level Agreement with East End Broadcast and The Bambury. This agreement has been in place for 4 years and continues until 2006-7

This agreement has been extremely successful and has led to numerous positive outcomes on an economic and or social context.

Hundreds of young people have participated each year on an outreach basis throughout the east end of Glasgow.

Please log on to [www.eeib/stats](http://www.eeib/stats) to observe website stats.

EEIB have recently purchased a broadcast quality DV Camera and an Apple Mac G5 with professional video editing software and a DVD burner. This equipment will for the basis of a small film unit which we intend to develop into a social economy project providing groups with the opportunity to have events shot and made into a DVD or to be trained in how to do so for themselves.

*Please continue to Section Seven on next page.*

## **SECTION SEVEN – Programming.**

**(For more information about the individual questions below, please refer to sections 7.1 to 7.10 of the accompanying notes).**

### **7.1 Programme Service**

We will provide a mix of Community Information, Music, Features on Local Groups/Activities and Discussion. While people like the novelty of hearing very localised information they still tend to expect “what they know” and therefore a certain amount of conventional music programming is required to engage with some of our intended listeners.

The station would therefore work to compete for listeners based on popular culture as it is perceived by our volunteer presenters, D.J’s., and by creating local interest by enabling volunteer’s family members and friends to hear broadcasts made by them.

We will strive to represent local culture and to promote cultural diversity and tolerance using music, chat and issue based discussions, soundbites.

**7.2** How will your proposed community radio service be different and distinct from existing (non-BBC) local radio services in the area concerned, and how will it broaden the range of programming offered in the locality? In addition, please explain how your proposed service will be of a nature or have a content distinct from that of any other local service with which it overlaps by fifty per cent or more in terms of population.

We will be broadcasting programmes recorded at the various Local groups we work with as well as output from local Schools such as concerts etc.

We will also include regular spots by local service providers providing information about issues specific to the area, including participation by service -users

We include regular spots for locally produced, original music to be played. This will be a priority and

### **7.3 Music and Speech Output**

We intend to run an initial ratio of 50% Music and 50% Speech based shows. The music content will contain a diverse range of Specialist Programmes along with some Popular Request Programmes.

The Speech output will be a mix of Interviews with Local people and Service Providers/Agencies, information programmes made in conjunction with organisations such as Citizen’s Advice, The Health Board and Council Services and Discussion Programmes on local issues.

### **7.4 Type(s) of music output included**

We currently and in future intend to run a variety of specialised music programmes as follows:-

60’s,70’s 80’s Lunchtime Request Show (20% of music output)

Electro Acoustic/Indie (8%)

Alternative/Rock (16%)

Easy Listening (8%)

Electronica/Northern Soul (8%)  
Unsigned Bands/Local Demos (12%)  
General Chart/Dance (20%)  
Happy Hardcore Dance (8%)

This will be reviewed on a quarterly basis.

**7.5** Type(s) of speech output included

We intend to have the following:-

Documentary shows about Local groups (20%)  
Interviews with Local People Characters (20%)  
Interviews with local Service Providers and Agencies (20%)  
Live and Pre-recorded Discussions on local issues. (20%)  
Live Entertainment/Review programmes (20%)

This will be reviewed on a quarterly basis .

*Section continues on next page...*

## **7.6 Details of Third party Programming Sources**

We currently have no plans to use any third party programming sources, however we will always be open to considering using good quality programmes if they are submitted to us provided they are relevant our community.

## **7.7 Broadcast Hours**

We initially intend to broadcast from 10am to 8pm (10 Hours) and then run a repeat loop of the day's programmes along with some pre recorded programmes overnight. (8pm – 10am)

We intend to gradually increase this to 6am to Midnight over the first couple of years.

We will be unable to broadcast live at weekends until planned upgrades to our present accommodation are completed. (within the next 18 months).

We shall continue to broadcast the best of the previous weeks broadcast on automated loop until this time.

## **7.8 Automated Output**

Our overnight broadcasting (8pm – 10am) will be broadcast via a playout system.

Our weekend broadcasting (8pm Friday – 10am Monday) will also be broadcast via a playout system.

This amount of automation will be reduced as we gain access to improved facilities in which we will have more control over entry and exit times.

## **7.9 Broadcast Languages(s)**

We initially only intend to broadcast in English, however we will look at the possibility of broadcasting in other languages should a demand for such arise.

We will work in partnership with the Scottish Refugee Council, Social Work Department, Glasgow Anti Racist Alliance etc. in order to provide translation services and to ensure appropriate Ethnic Minority representation.

We would also encourage Modern Languages to be promoted through schools etc. linking with Primary and Secondary Schools

## **7.10 Commencement Date**

The earliest date at which we'd like to start broadcasting would be April/May 2005.

*Please continue to Section Eight on next page.*

**SECTION EIGHT - Finance**

**(For more information about the individual questions below, please refer to sections 8.1 to 8.5 of the accompanying notes).**

**8.1 Capital, Set-Up Funding and Financial Support:**

Provider of funds (name and address, status of provider e.g. charitable foundation, company etc.)	Is funding in cash or in kind?	Is this funding secured? Impact if funding is not secured / contingency arrangements.	Terms and conditions placed on funding (if any).	% of Funding	Amount of Funding (£s).
Glasgow East End Social Inclusion Partnership Gallowgate, Glasgow	Cash	Secured until 2006 Developments thereafter will be subject to "Community Planning Partnerships"	To deliver services throughout the East End SIP area in accordance with the SIP strategy.	29%	42,000
John Wheatley College Westerhouse Road Easterhouse, Glasgow	In Kind (Widening Access Fund)	Secured until 2006 Developments already underway to build new Campus in the heart of the east end. Broadcasting/Sound Engineering studios included in plans. Widening Access funding likely to be accessed by EEB as currently agreed.	To deliver services to the East End of Glasgow by delivering ICT, Creative Industries Learning Opportunities in partnership with the Bambury Centre as part of the current Service Level Agreement.	34%	50,000
The Bambury Regeneration Centre 67 Yate St, Camlachie Glasgow, G31 4AE	Cash	Secured until 2006	To deliver services throughout the East End in accordance with the Local regeneration strategy.	29%	42,000
Glasgow City Council Youth Initiative	Cash	Secured until 2005.	To deliver services to young people who are hard to reach and /or vulnerable throughout the East End in accordance with GCC Youth Policy	8%	12,500
			<b>Total Capital, Set-Up Funding and Financial Support:</b>	<b>100%</b>	<b>146,500</b>

(Please continue on an additional sheet if necessary).

## SECTION EIGHT – FINANCE (continued)

**8.2** Capital and Set-Up Expenditure:

Item	Details	£s
Premises (including refurbishment and fitting out costs).	Premises in place as part of current funding	
Transmission Equipment:	Power Amp and Antenna = £4000, Test Gear - £1500. Installation, Calibration & Testing costs = £1500	£7,000
Studio Equipment:	Currently in place. Upgrading	
Pre-Launch Publicity and Marketing (if any):		
Other one off costs (please specify)	Wireless Telegraphy Act Fees (£509) Broadcasting Act Fees (£600)	£1,109
Capital equipment already owned by group (at current replacement value)	Please See attached inventory.	£33,765
Working Capital (Contingency Reserves)		
	Total set up costs	£41,874

(Please continue on an additional sheet if necessary).

*Section continues on next page...*

## SECTION EIGHT – FINANCE (continued)

## 8.3 Operating Costs

OUTGOINGS	Pre Launch Budget		Year 1 Budget				Year 1 Totals (£s)
	Pre-launch 6 to 3 months (£s)	Pre-launch Quarter (£s)	On-Air Quarter 1 (£s)	On-Air Quarter 2 (£s)	On Air Quarter 3 (£s)	On-Air Quarter 4 (£s)	
Hp/Leasing	None	None	None	None	None	None	None
General and Administration							
- Staff	18,000.	18,000	18,000	18,000	18,000	18,000	72,000
- Premises	1,250	1,250	1,250	1,250	1,250	1,250	5,000
- Legal and Professional							
- Establishment/overheads							
Engineering							
- Transmitter operating costs			750	750	750	750	3000
- Other (specify)							1000
- Eng Consultant Fees		1000					
Programming							
- Copyright fees			257.50	257.50	257.50	257.50	1030
- Music library	300	300	300	300	300	300	1200
- Acquired programming	None	None	None	None	None	None	None
- News service	None	None	None	None	None	None	None
- Other (specify)	None	None	None	None	None	None	None
Sales cost/commissions (where appropriate)	None	None	None	None	None	None	None
Marketing and promotion (where appropriate)			2000	2000	1000	1000	6000
Audience research (where appropriate)	0	0	300	200	0	0	500
Others (please specify)	None	None	None	None	None	None	None
<b>Total Outgoings</b>							<b>89,730</b>

Section continues on next page...#

## SECTION EIGHT – FINANCE (continued)

## 8.4 Annual Income and Revenue Funding (Year 1)

Provider of funds (name and address, status of provider e.g. charitable foundation)	Is this funding in cash or in kind?	Is this funding secured, impact if funding is not secured / contingency arrangements?	Terms and conditions placed on funding (if any):	Anticipated % of Funding	Amount of Funding (£s) (Year 1).
East End Social Inclusion Partnership Management Board	Cash	Secured until 2006	To deliver services within the East End	29%	42,000
John Wheatley College	In Kind	Secured until 2006	To deliver services within the East End	34%	50,000
The Bambury Regeneration Centre	Cash	Secured until 2006	To deliver services within the East End	29%	42,000
Local Action Fund	Cash	Pending March/April 2006	To deliver services to Young People within the East End	8%	12,500
<b>Total Income and Revenue Funding:</b>				<b>100%</b>	<b>146,500</b>

## Commercial and other sources.

Type of Income and Revenue Funding.	Anticipated % of Funding	Amount of Funding £s.
On-air spot advertising	<b>None</b>	<b>None</b>
Programme sponsorship	<b>None</b>	<b>None</b>
Other commercial revenues (off-air sponsorship, merchandising etc.). Please specify.	<b>None</b>	<b>None</b>
Other non-commercial revenues (fund-raising, subscriptions, donations etc.). Please specify.	<b>None</b>	<b>None</b>
<b>Total Income and Revenue Funding:</b>	<b>100%</b>	<b>None</b>

## SECTION EIGHT – FINANCE (continued)

### 8.5 On-Air Commercial Activities

Do you intend to seek commercial revenues?	Yes: (tick) ?	OR No: (tick) <b>No</b>
Will your proposed station carry on-air spot advertising?	Yes: (tick) ?	OR No: (tick)No <b>No</b>
Will your proposed station carry on-air programme sponsorship?	Yes: (tick) ?	OR No: No(tick) <b>No</b>

What contingencies are in place in case commercial revenues for the proposed service do not achieve the anticipated levels?

The project will not rely on commercial revenues on the first year as we exist in order to engage people in Learning, however we will exercise the opportunities allowed within the licence and plan and project our targets after the appropriate measures have been considered and further funding opportunities from current sources have been decided upon .

The project will consult the Community Planning Partnership Board in 2005 regarding the potential commercial revenues which could be available.

The current SIP board are in favour of the project becoming less dependant on SIP funding and are likely to recommend that we utilise the commercial, advertising and sponsorship opportunities that would arise if the application were to be successful.

The Bambury Centre would manage these Financial Activities in accordance with the Bambury Phase 2 plans to provide arts/multi-media/training opportunities and employment opportunities.

The project will continue to build on previous success in providing Training For Work and other initiatives for unemployed people from the east end.

These workers will learn various skills which will enable them to simulate freelance work via the project, providing information using multi media tools and ICT( design, music, engineering, video production, website design, graphics)

These placements will inevitably lead to opportunities for people to increase their earning capacity through learning new skills and increased confidence and awareness.

It is already apparent that a number of people have gained employment as a result of learning at the Bambury Centre, including work in the arts and media.

The Project will consider the commercial and other options as part of the Bambury Phase 2 developments, including the possibility of potential social economy projects which would be allowed more freedom to to earn revenue

There is no doubt that the project can raise funds by providing services to

agencies such as housing Associations and some sponsorship, adverts etc., however the mainstay of our funding will continue to come from the current sources for the first year and we would be unsure of any projections until late 2005

We will broadcast on F.M. if successful and evaluate the first 6 months. Funding applications will continue to sustain the project and we will maximise the commercial aspects of our services based on the requirements of the funders, who may limit the commercial gain of the project to some extent, as well as Ofcom.

We hope to attract funding from various sources, however it is prudent for us to aim for a licence within our current funding package timescales, rather than speculate on commercial gain or continuation funding during a transition process from SIP to CPP's.

*Please continue to Section Nine on next page.*

## SECTION NINE - Engineering

(For more information about the individual questions below, please refer to sections 9.1 to 9.12 of the accompanying notes).

9.1 Please provide a description of your proposed transmission site

The Bambury Regeneration Centre
---------------------------------

9.2 Please provide a National Grid Reference for your proposed transmitter site:

National Grid Reference	=	616 642
-------------------------	---	---------

9.3 Please tick this box to confirm you have included a map showing your proposed transmitter site location and the expected transmission coverage from it:

Map supplied: (tick) <b>Yes</b>
---------------------------------

9.4 Please tick this box to confirm you have included a photograph of your proposed transmitter site

Photograph supplied: (tick) <b>Yes</b>
--

9.5 Site Availability. Please tick those boxes below which best describe your group's situation regarding your proposed transmitter site(s).

Site Identified	<b>Yes</b>
-----------------	------------

Agreement in Place:	<b>Yes</b>
---------------------	------------

Under Negotiation	
-------------------	--

Group Owns Site	<b>Yes</b>
-----------------	------------

Site not yet identified	
-------------------------	--

*Section continues on next page...*

**9.6 Antenna Details**

(a) FM – Height of Antenna above Ground Level.

30	Metres.
----	---------

(b) AM – Height of Transmitting Antenna.

N/A	Metres.
-----	---------

(c) AM & FM – Assumed height of local ground above sea level.

19	Metres.
----	---------

**9.7 Radiated Power.** Please complete the appropriate sections below.

(a) If you are proposing to operate on AM, please give the Effective Monopole Radiated Power (EMRP) level you expect to need in order to cover your proposed service area.

N/A	Watts.
-----	--------

(b) If you are proposing to operate on FM, please give the Effective Radiated Power (ERP) level you expect to need in order to cover your proposed service area. (Vertical Polarisation).

25	Watts.
----	--------

(c) If you are proposing to operate on FM, please give the Effective Radiated Power (ERP) level you expect to need in order to cover your proposed service area. (Horizontal Polarisation) (if used).

25Watts (proposed to counteract effect of neighbouring buildings affecting optimum coverage)	Watts.
--	--------

*Section continues on next page...*

(d) Radiation (polar) Pattern. Please tick the appropriate box. If you tick the 'Directional' box, please enclose horizontal radiation diagram(s), for the vertically polarised signal component, and for the horizontally polarised signal component (if used).

Omni – Directional	YES	Directional
--------------------	-----	-------------

Diagram of Vertically Polarised signal component included	?	Diagram of Horizontally Polarised signal component included	?
---	---	---	---

**9.8 Engineering Compliance.**

Primary responsibility for Transmissiom Equipment will rest with the EEB Station Coordinator assisted by WA Jarvie (Professional Consultant Engineer)

Test Units will be provided which and access to all monitoring points to enable OFCOM Engineers to carry out various regulatory Compliance Checks.

To provide best reliability and ensure compliance with OFCOM Engineering Code EEB policy is to use professional standard transmission equipment.

**9.9 Principal Transmission Equipment.**

(a) Transmitter (Manufacturer) (model)

Radica	FM5 5Watt Transmitter
Radica	50 Watt Power Amplifier

(b) Antenna (Manufacturer) (model)

Jaybeam (or similar)	Band 2 Broadcast Antenna
----------------------	--------------------------

(c) Limiter / Processing (manufacturer) (model)

Behringer (located in Studio)	MDX-1200
----------------------------------	----------

(d) Please provide a description of how these items of equipment will be configured, including details of any additional filtering you consider may be required.

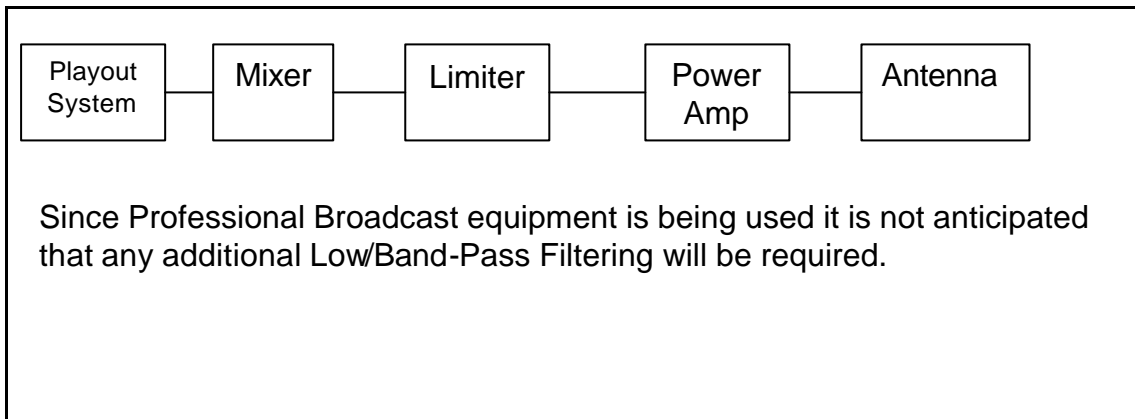

*Section continues on next page...*

(e) Please provide details of the gain calculations used to arrive at the estimated ERP / EMRP figure required to cover the proposed service area of your station.

Transmitter Output Power = 44.5Watts

Anticipated feeder loss = 1db = 9.1Watts

Power to the Antenna System = 44.5 – 9.1 = 35.4 Watts

Antenna System Gain = 1.5 db = 50 Watts ERP

Split by the Antenna into 25 Watts Vertical + 25 Watts Horizontal

**9.10** Radio Data System (RDS). If you are proposing to operate an FM service and want to transmit RDS data, please tick the box marked '**Yes**', otherwise, tick '**No**'.

Yes: (tick) <b>YES</b>	No: (tick)
------------------------	------------

**9.11** Transmitter Maintenance and Repair.

Transmission will be monitored on a daily basis for any signs of frequency drift, excess deviation or audio distortion.

First line transmitter Maintenance and repair will be carried out in-house.

Equipment Available will include a Frequency Meter, RF Power Meter, Frequency Generator and Electrical Test meter.

Where the use of calibrated test equipment such as a Spectrum Analyser is required we shall rely on a specialist outside contractor.

**9.12** Studio Location

We will continue to use the existing Studio Space in :-

The Bambury Centre.

67 Yate St

Camlachie

Glasgow G31 4AE

The Studio is one of a number of Spaces owned by The Bambury and made available to the EEB.

We intend to move the Studio to a specially converted suite in a different part of the Centre once a planned extension to the building has been completed.

*Please continue to Section Ten on next page.*

**SECTION TEN - Concluding Declaration.**

**Do you confirm that, to the best of your knowledge and belief that:**

- (1) The applicant is not a disqualified person in relation to the licence by virtue of the provisions of section 143 (5) of the Broadcasting Act 1996 (relating to political objects);**
- (2) No director, member or other person involved directly or indirectly in the management of the applicant group is the subject of a disqualification order as defined by section 145 (1) of the Broadcasting Act 1996;**
- (3) No person involved in the application has been convicted within the past five years of an unauthorised broadcasting offence and that the applicant will do all it can to ensure that no person so convicted will be concerned in the provision of the service, the making of programmes included in it, or the operation of the radio station if the applicant is granted a licence; and**
- (4) Any matters which might influence Ofcom's judgement as to whether the directors or members of the applicant group are fit and proper persons to participate in a radio licence have been made to Ofcom.**

**Applicants should note that Ofcom reserves the right to revoke a licence if at any time any material statement made is found to be false and to have been made by the applicant or any member or officer thereof knowing it to be false, and that in the circumstances of section 144 of the Broadcasting Act 1996, the provision of false information or the withholding of relevant information with the intention of misleading Ofcom could incur a criminal conviction and a disqualification from the holding of a licence.**

**I agree that the applicant conforms with the above**

**Yes**

**The ticked boxes below indicate which additional documentation is included as part of this application:**

Memorandum & Articles of Association	<b>Yes</b>
Certificate of Incorporation	<b>?</b>
Map of proposed transmitter site	<b>? Yes</b>
Photograph of proposed transmitter site	<b>? Yes</b>
Antenna pattern information	<b>?</b>

*Declaration continues on next page...*

Others Documents (please provide details in box below)

?

**( Please Note that due to equipment failure we have been unable to scan any documents and will therefore be sending them by post)**

Appendix to Application Form

Application Payment (UK £ 600.00) non-returnable ?

**I hereby apply to Ofcom for the grant of a licence for the Community Radio Licence described above and declare that the information given in this application and any additional documentation is, to the best of my knowledge and belief, correct.**

Name:	Sam Paterson
Position:	Multi-Media Manager
Date:	23/11/04

Please tick this box to confirm that you have kept a copy of this completed application form for your records.	Yes
--	-----

<b>Please tick this box to confirm that you have completed this form as completely as possible and that you have attached / sent any required additional documentation, together with the non-returnable application fee of £600.00</b>	Yes
---	-----

Please return this form and any additional electronic information by e-mail to:

[communityradio@ofcom.org.uk](mailto:communityradio@ofcom.org.uk)

If there is any paper-based material associated with this application, please send it to:

Community Radio Licensing  
Radio Planning & Licensing Team 3rd Floor  
Ofcom  
Riverside House  
2A Southwark Bridge Road  
London  
SE1 9HA

*Please make sure you keep a copy of this form for your records.*